

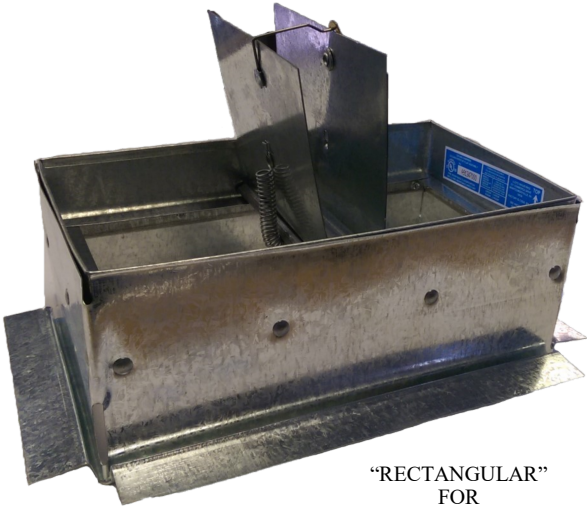

ROLL FORMED SLEEVE FOR CEILING RADIATION DAMPER

**MODEL:
I-CRD50
I-CRD50-EA**



"RECTANGULAR"
FOR
INSTALLATIONS

APPLICATION

Model I-CRD50/ I-CRD50-EA is an 1-Hour rated ceiling radiation damper with sleeve. The damper is UL fire rated for Ceiling/Floor and Ceiling/Roof Assemblies L528, L558, L562, L563, L574, L585, M562, P533, P544, P545, P547, and P580.

Contact us for additional applicable Ceiling/Floor and Ceiling/Roof Assemblies.

Model I-CRD5-/I-CRD50-EA is a CRD with 26gauge **ONE PIECE ROLL FORMED SLEEVE**. It saves time and money by just sliding in and attaching by spot welds/ rivets. Measurement are not required.

CEILING RADIATION DAMPER

- Fusible Link: 165°F standard (optional: 212°F)
- Blades: 22 Ga. (0.853mm) Galv. Steel
- Frame: Roll formed 22 Ga. Galv. Steel
- Sleeves: **26 Ga. one piece roll formed**

INSTALLATION INSTRUCTIONS AND THE PRODUCTS SPECIFIED, ARE IN CONFORMANCE TO ALL OF UNDERWRITERS LABORATORIES REQUIREMENTS 555C

Meets NFPA 90A Requirements

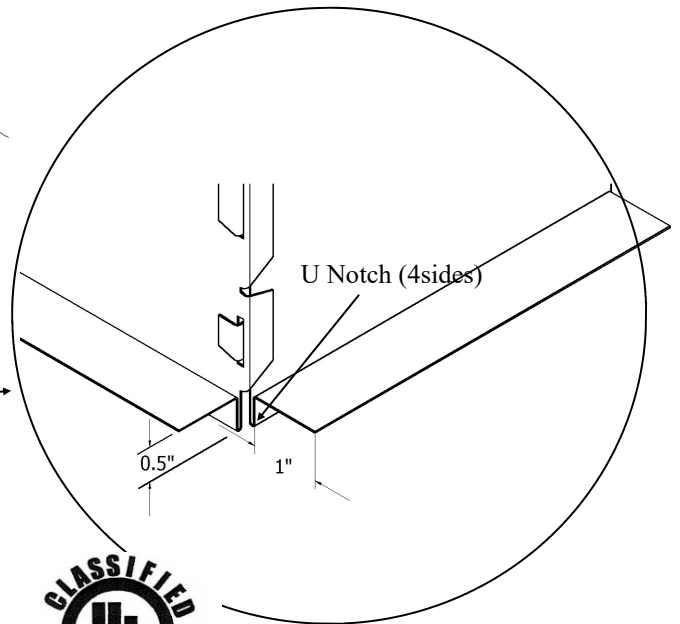
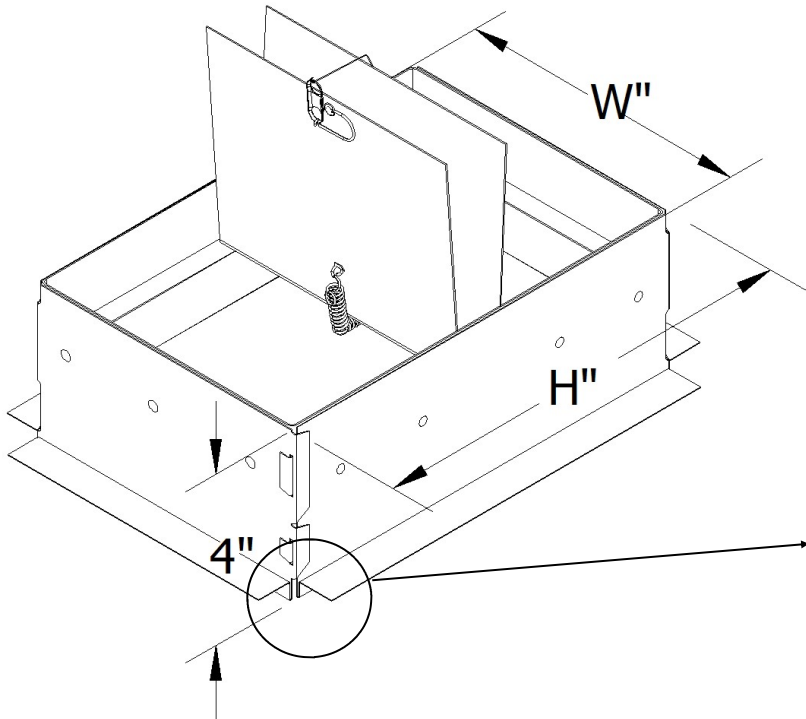

Note:
Ceramic insulation is not UL required on dampers with areas less than 80 sq.in and is optional dampers above 80 sq.in will be provided with blade insulation.

