



# COMBINATION FIRE SMOKE DAMPER



**MODELS:**  
**FSD-111-1-PB**  
**FSDL-111-1-PB**

### APPLICATION

The FSD-111-1PB is a class 1 ultra low leakage, 1-1/2 combination fire & smoke damper with 3 "V" blades. The FSD-111-1PB can be installed vertically or horizontally in HVAC systems and is rated for airflow and leakage in either direction. The FSD-111-1PB has been tested with velocities up to 2000 fpm (24"x24" 4000fpm) and pressures to 4.0 in. w.g.

### STANDARD CONSTRUCTION

- FRAME:** 16 Ga. (1.5mm) galvanized steel  
Interlocking stacked hat section  
Channel frame construction
- BLADES :** 16 Ga. galvanized 3 "V" formed  
Parallel blade
- BEARINGS:** Sintered bronze, oil impregnated
- AXLES:** 1/2 Sq. zinc plated steel studs
- LINKAGE:** 0.12x0.50 Zinc plated steel  
concealed in the channel frame
- FINISH:** Mill galvanized
- BLADE SEALS:** 60-65 Durometer silicone rubber  
with laminated acrylic adhesive  
permanently bonded to blade edges.
- JAMB SEALS:** Corrosion resistant stainless steel
- JACKSHAFT:** 1/2" Dia. Zinc plated steel with  
jackshaft connector coupling
- SLEEVE:** Rectangle, round, oval or special
- FUSIBLE LINK:** 165 Degree

### RATINGS

- Fire rating: 1-1/2 Hours or FSDL 3 Hours
- Ultra low leakage: Class 1
- Installations: Vertical/ Horizontal
- Maximum velocity: 2000fpm (24"x24" 4000fpm)
- Maximum static pressure: 4.0" W.G.
- Temperature rating: 250° F/350° F
- Operation rating: Power open/ Spring closure

### UL CLASSIFIED: UL 555 &UL 555S

Model FSD-111-1-PB meets the requirements for fire dampers, smoke dampers and combination fire smoke dampers established by:

- CSFM California State Fire Marshal  
Fire Damper Listing (#3225-1417:102)**
- Leakage (Smoke) Damper Listing (#3230-1417:103)**
- British Standard (BS – 476 Part 20)**
- Performance testing by AMCA International  
(AMCA STD 500)**
- HKFM Hong Kong fire Marshal Approval**



### OPTIONS:

- Stainless steel frame
- Fusible link 212 degree
- Lloydstat
- LS-200
- Smoke Detector (Model D4120 or B114LP)
- FSDL (FIRE RATING 3 HOURS)

### ACTUATOR:

- Specify type: electric or pneumatic
- Specify brand: SIEMENS, BELIMO, HONEYWELL
- Specify mounting: external or internal
- Specify voltage: 24V, 120V, 220V

Single Section		Multiple Section
Minimum Size (WxH)	Maximum Size (WxH)	Maximum Size (WxH)
8"x8" (external mount)	(internal mount) 10"x10"	36"x36"
		72"x72" (vertical)
		120"x72" (vertical)
		96"x72" (Horizontal)

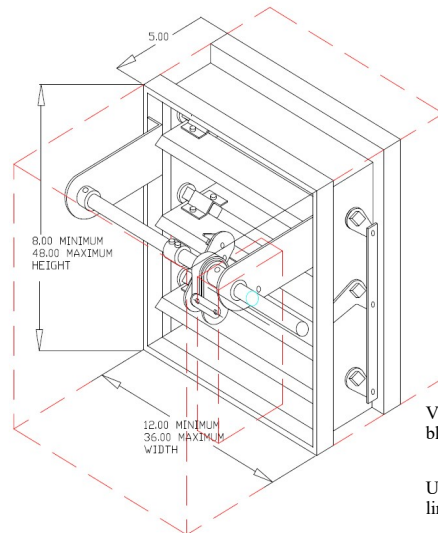

Vertical mount parallel blade damper shown

Used with fusible links 165°F

231 Commerce Dr. Montgomeryville, PA 18936  
Tel: 215-412-4445 Fax: 215-412-4409  
Email: lloydind@firedamper.com

138 Industrial Loop West, Orange Park, FL 32073  
Tel: 904-541-1655 Fax: 904-541-1657  
Email: lloydind1@firedamper.com

B1, 4/F., Luen Ming Hing Factory Building  
36 Mok Cheong St.,  
To Kwa Wan, Kowloon, H. K.  
Tel: 852-2760-4188 Fax: 852-2760-4177  
Email: tatanlexyim@lloydasia.com

