



# FIRE SMOKE DAMPER WITH SMOKE DETECTOR

**MODELS:**  
**FSD-111-1-PB-B114LP**



### APPLICATION

The FSD-111-1PB-B114LP is a fire smoke damper with a plug-in smoke detector. The smoke detector is UL 268A listed specifically for use in no-flow/low-flow air-handling systems. It's designed for installation where a standard venturi principle duct smoke detector is unsuitable. This is the perfect combination for installation in ducts where the air velocity is below 500 fpm or for duct size as small as 8 inches in diameter.

### RATINGS

Fire rating:	1-1/2 Hours or FSDL 3 Hours
Ultra low leakage:	Class 1
Dynamic closure rating:	Actual limits are size dependent
Maximum velocity:	2000fpm
Maximum pressure:	4.0" W.G.
Temperature rating:	250° F/350° F

### STANDARD CONSTRUCTION

- FRAME:** 5in. X 1in. Channel
- 16 Ga. (1.5mm) galvanized steel
- BLADES :** 16 Ga. 3V
- BEARINGS:** Bronze
- AXLES:** 1/2 Sq. zinc plated steel studs
- LINKAGE:** 0.12x0.50 Zinc plated steel  
concealed in the channel frame
- FINISH:** Mill galvanized
- AIR FLOW:** Bi-Directional
- JACKSHAF:** 1/2" Dia. zinc plated steel with  
jackshaft connector coupling
- SLEEVE:** Minimum Length: 18"
- FUSIBLE LINK:** 165 Degree

### OPTIONS:

- Stainless steel construction
- Fusible link 212 degree
- Lloydstat
- LS-200
- FSDL (FIRE RATING 3 HOURS)

### ACTUATOR:

- Specify type: electric or pneumatic
- Specify brand: SIEMENS, BELIMO, HONEYWEL
- Specify mounting: external or internal
- Specify voltage: 24V, 120V, 220V

Model FSD-111-1-PB-B114LP meets the requirements for fire dampers, smoke dampers and combination fire smoke dampers established by:

- CSFM California State Fire Marshal**
- Fire Damper Listing (#3225-1417:102)**
- Leakage (Smoke) Damper Listing (#3230-1417:103)**
- British Standard (BS – 476 Part 20)**
- Performance testing by AMCA International**
- HKFM Hong Kong fire Marshal Approval**

(AMCA STD 500)

**UL CLASSIFIED:** UL 555 & UL 555S

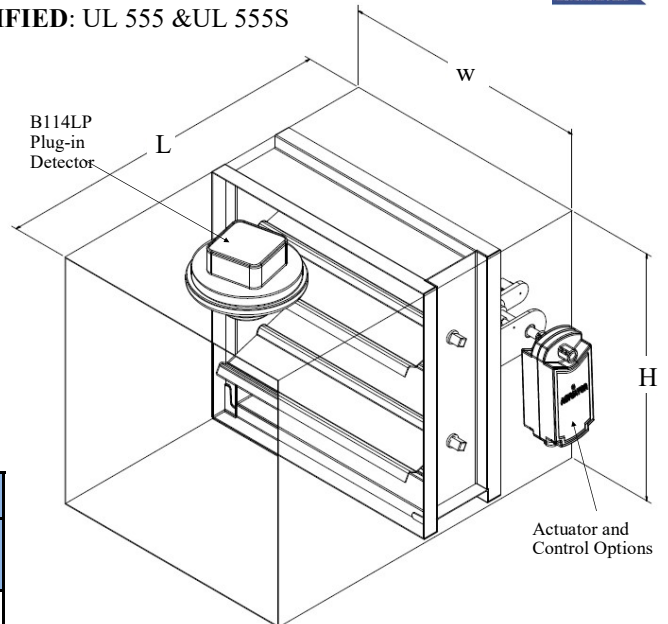

**NOTE:**  
Dampers supplied 1/4" less than order width and height unless specified "ACTUAL SIZE"

Single Section		Multiple Section
Minimum Size (WxH)	Maximum Size (WxH)	Maximum Size (WxH)
8"x8" (external mount)	(internal mount) 10"x10"	36"x36"
		72"x72" (vertical)
		120"x72" (vertical)
		96"x72" (Horizontal)

231 Commerce Dr. Montgomeryville, PA 18936  
Tel: 215-412-4445 Fax: 215-412-4409  
Email: lloydind@firedamper.com

138 Industrial Loop West, Orange Park, FL 32073  
Tel: 904-541-1655 Fax: 904-541-1657  
Email: lloydind1@firedamper.com

B1, 4/F., Luen Ming Hing Factory Building  
36 Mok Cheong St.,  
To Kwa Wan, Kowloon, H. K.  
Tel: 852-2760-4188 Fax: 852-2760-4177  
Email: tatanlexyim@lloydasia.com

