



CEILING RADIATION DAMPER WITH REGISTER BOX ASSEMBLY

**MODEL:
CRD4X-NI-BT-26GS**



APPLICATION

Model CRD6X-NI-BT-26GS is an 1-Hour rated CRD/Register/Grille assembly. The damper is UL fire rated for Ceiling/Floor and Ceiling/Roof Assemblies L528, L558, L562, L563, L574, L585, M562, P533, P544, P545, P547, and P580. Contact us for additional applicable Ceiling/Floor and Ceiling/Roof Assemblies.

TYPE CRD: Rectangular damper with non-insulated register box, "side outlet".

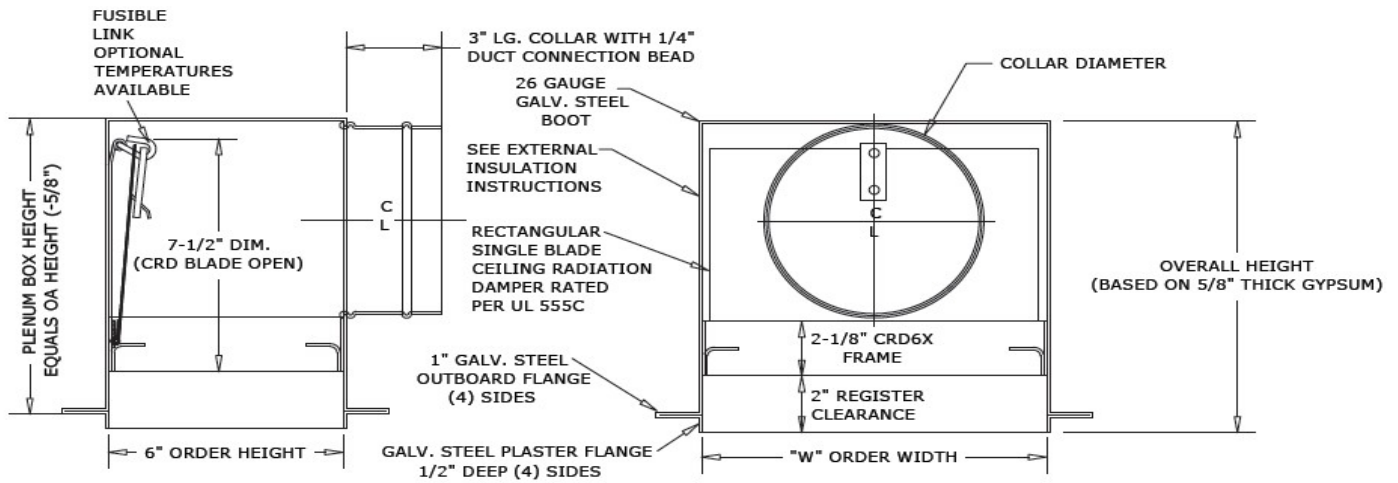

CEILING RADIATION DAMPER

- Rating: UL listed ceiling radiation damper UL-555C
- Fusible Link: 165°F standard
- Blades: 22 Ga. galvanized steel
Ceramic Fiberglass Cover (for total blade area > 80 sq. in.)
- Frame: Roll formed 22 Ga. galvanized steel

PLENUM BOX

- Outer Box: 26 Ga. galvanized steel
- Collar: Roll formed 26 Ga. galvanized steel
- Insulation: None provided
- "C" Diameter provided nominal order diameter (-1/4")

NOTES:

- Manufactured with blades open as shown.
- Ceramic insulation is not required on damper blades with W x H areas less than 80 SQ/IN.
- Register/Grille supplied by other.

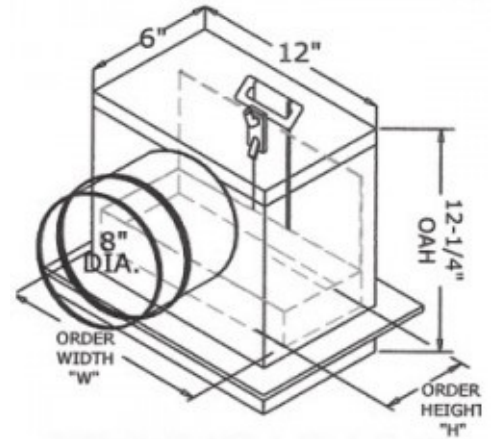

Minimum Size (WxH)	Maximum Size (WxH)
6"x4"x4" (collar)	14"x4"x8" (collar)

