



## EXTRUDED ALUMINUM BRICK VENTS

**MODELS:  
4-BVCF  
(CHANNEL FRAME)**



### APPLICATION

The 4-BVCF is an extruded aluminum brick vent with channel frame. Extruded construction provides a quality finished appearance. A high water stop at the rear and deep overlapping blades with storm stops provide maximum resistance to rain.

### STANDARD CONSTRUCTION

- FRAME:** 1/8" Thick extruded aluminum 6063 T6  
Construction with 1/4" drip ledge top and bottom
- BLADES:** 1/8" thick extruded aluminum 6063 T6 construction
- BLADE CENTERS:** 1" Centers at 45° head and sill spacing not to exceed frame flange dimension for maximum water resistance
- INSECT SCREEN:** Aluminum 18x16 MESH corrosion resistant
- FINISH:** Mill finish
- OPTIONAL FINISHES:** Clear Anodize  
Black Enamel Paint  
Powder Coat Paint  
KYNAR  
Bronze Anodize
- SIZES:** Minimum Width 4"  
Minimum Height 2-1/4"  
Maximum single section: Unlimited

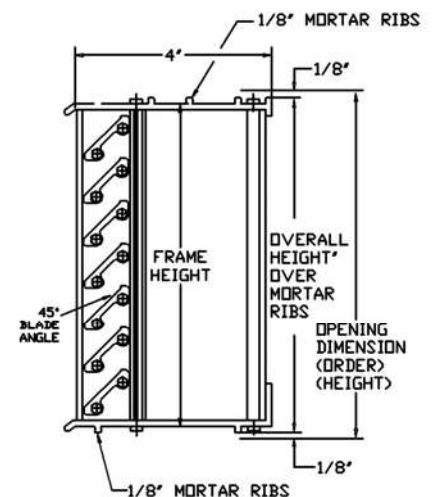
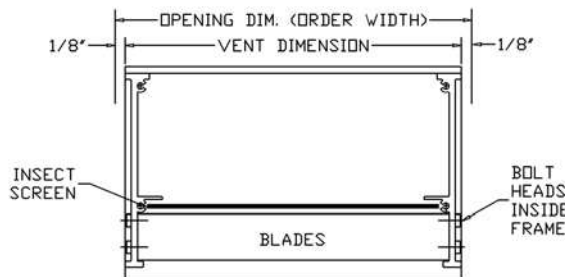
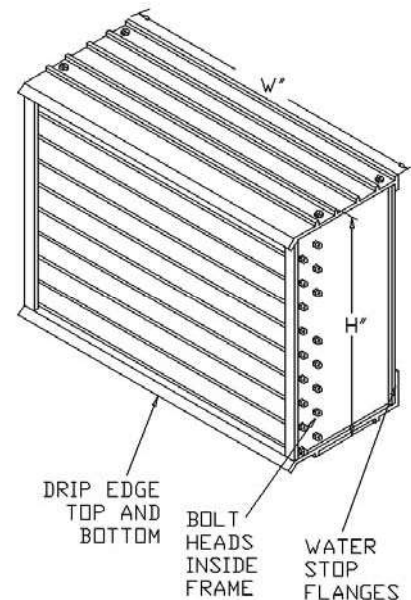

Brick vent will be supplied as order width -1/4" x order height -1/4" unless specified "actual size."

