



ACCESS DOORS



60-RHAD



65-RCAD

Standard models are 1" thick hinged or double cam lock insulated doors.

**MODEL:
60-RHAD
65-RCAD**

Standard Construction

- Frame:** 22 Ga. galvanized steel
- Door Panel:** 22 Ga. galvanized steel
- Finish:** Galvanized steel

- 1" Thick double cam round duct access door
- Double panel door
- Frame 26 Ga. galvanized steel
- Varied duct diameter radius
- 1/4' X 1/2' Wide gasketing

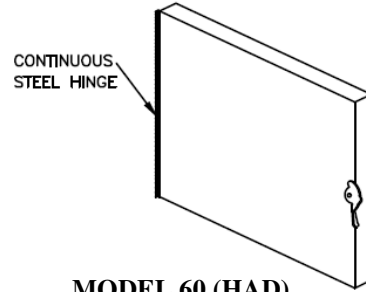

MODEL 60 (HAD)
Hinged 1" access door with insulation

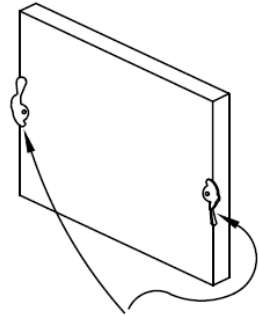

MODEL 65 (CAD)
Double cam 1" access door with insulation

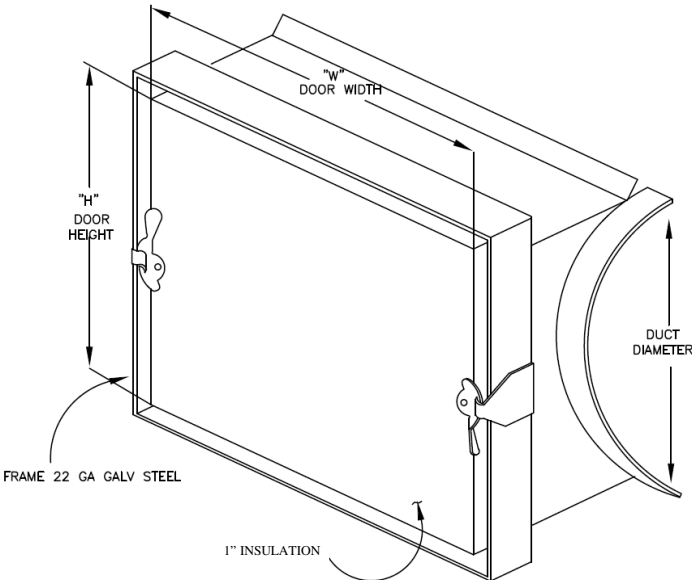

NOTE:

1. Hinged doors over 14" x 14" have 3 cam latches. Double cam doors over 14" x 14" have 4 cam latches.
2. All models include 1/8" thick x 1/2" wide door-to-frame gasket.

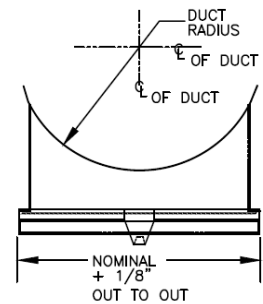

Optional Material:
Aluminum or stainless steel

1/4"-THICK X 1/2"-WIDE GASKETING
HINGED (RHAD) DOOR SHOWN

