

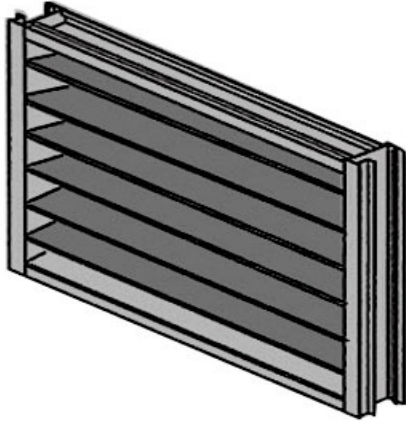

EXTRUDED ALUMINUM LOUVER

MODEL: 2-SRCF COMBO COMBINATION INTAKE/EXHAUST



APPLICATION

The 2-SRCF COMBO Stationary Louver is 2" deep with a Channel Frame. Which is for the protection of higher air intake and exhaust velocities in building exterior walls. The louver structure incorporates stationary 36° and 90° blades. The 2-SRCF COMBO is AMCA STD 500 approved.

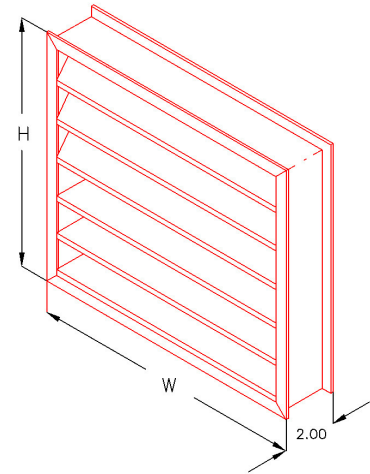

SPECIFICATIONS

- Frame:** 0.081 thick extruded aluminum
6063-T5 mill finish
- Blade:** 0.081 thick extruded aluminum
6063-T5 mill finish
- Blade Spacing:** Approximately 3-1/4" center to center
(except at head and sills)
- Fasteners:** 10" x 3/4" tek screws
- Blade Angle:** 36° and 90°
- Min. Height:** 12"
- Max. Single Sec.:** Consult factory for maximum size
- Screen:** Bird screen 1/2"x1/2" galvanized steel

OPTIONS

- Insect Screen 1/16" x 1/16" mesh aluminum
- Bird Screen 1/2" x 1/2" aluminum

- Finish:** Clear Anodized
- Bronze Anodized
- Powder Coat Paint
- Baked Enamel Paint



1/2" MESH ALUMINUM WIRE BIRD SCREEN

